



# AIL BALL VALVES

---

**REGULAR BORE**  
**FULL BORE**  
**TRUNNION MOUNTED**

**BS 5351**

**BS 5159**

**API 6D**



**AUDCO INDIA LIMITED**

AIL  
BALL  
VALVES

**AUDCO INDIA LIMITED (AIL)** is a leading manufacturer of Ball Valves, with a strong presence in India and overseas.

AIL has three manufacturing facilities. The main plant is located in Manapakkam, Chennai. The two other plants are at MM Nagar, 40 kilometres south and at Kancheepuram, 70 kilometres west of the main plant. The plants are equipped with specialised production facilities with special purpose machines, automatic welding equipment, heat treatment furnaces and testing equipment for total control of all manufacturing operations. In-house metallurgical and NDE laboratories, and gauge calibration facilities with up to date equipment provide support to ensure the quality of products manufactured.

AIL manufactures a wide variety of industrial valves with ISO 9001 certified Quality Management System in all three plants. AIL is also licenced to use the API 6D monogram.

The **AIL Ball Valve** has established itself as the industry standard for quality, integrity, reliability and long service. The valves are manufactured to the latest international designs, using advanced manufacturing techniques and stringent quality control checks.

### **FEATURED IN THIS CATALOGUE ...**

#### **AIL BALL VALVES - ADVANTAGES**

- Salient features

#### **FLOATING BALL VALVES**

##### **Reduced Bore**

- Three-piece
- Single-piece / Two-piece

##### **Full Bore**

- Three-piece
- Single-piece / Two-piece

##### **Special Purpose**

- Steam Service
- Cryogenic Service
- High Pressure Service
- Multiport Valves
- High Temperature Service

#### **TRUNNION MOUNTED BALL VALVES**

##### **Reduced Bore**

- Two-piece

##### **Full Bore**

- Two-piece

#### **PNEUMATIC ACTUATORS FOR BALL VALVES**

- Double Acting
- Spring Return

#### **TECHNICAL DATA**

- Pressure-Temperature Graphs
- Flow Coefficients
- Materials of Construction

#### **ORDERING INFORMATION**

- Figure Numbering

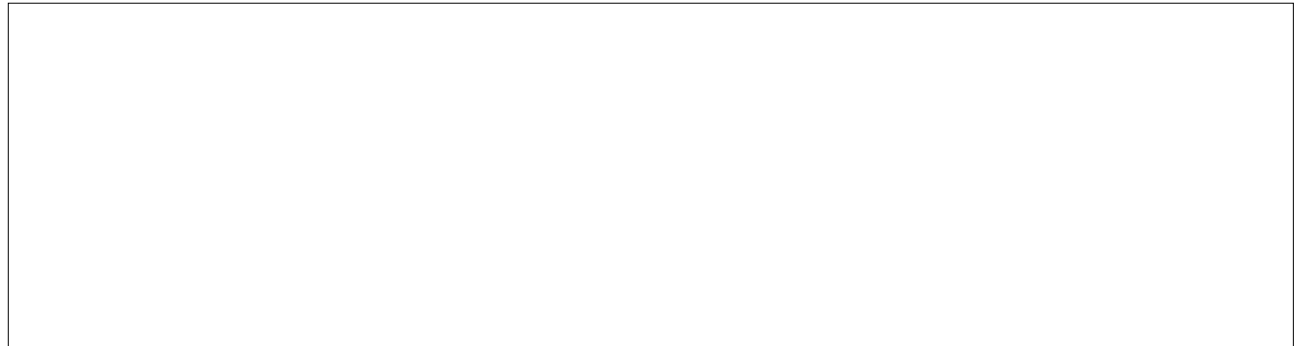

### **FLOATING BALL**

AIL manufactures both floating and trunnion-mounted ball valves. The standard AIL Ball Valve is of a floating-ball design, where sealing takes place by allowing the ball under pressure to move towards the downstream seat to effect a tight seal. The floating ball design is the universal choice for most process and utility applications.

### **THREE-PIECE DESIGN**

Ball Valves featuring this design are the most easily on-line maintainable in their class. By removing three body connector bolts and loosening the fourth, the body can be swung away using the fourth bolt as the fulcrum, to carry out any installation or maintenance operation on the valve. This feature reduces maintenance downtime to a bare minimum.

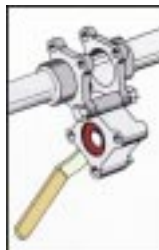

### **TRUNNION-MOUNTED BALL**

For higher sizes and pressure ratings, and for special services that require double-block and bleed features, trunnion-mounted ball valves are preferred by industry. In this design, sealing takes place by allowing the seat to move towards the ball along the flow axis. AIL manufactures a comprehensive range of trunnion-mounted ball valves, both in welded joint and in bolted body joint construction. These valves come with metal seats for cross-country pipeline applications and with soft seats for critical process applications.

### **SINGLE-PIECE / TWO-PIECE DESIGN**

Single-piece ball valves are high performance valves, which come with a one-piece integrally flanged body, in sizes of up to 200mm reduced bore and 40mm full bore. This design offers the unique advantage of eliminating the possibility of external leakage to the atmosphere through bolted body joints. These environment-friendly and high-integrity valves are preferred in critical applications where the media is expensive, volatile or toxic, and where external leakage or wastage is unacceptable.

The two-piece design complements the single-piece design in sizes of 250mm and above reduced bore, and 50mm and above full bore.



# Salient Features

A number of outstanding features in the AIL Ball Valve serves you with the ultimate user advantage. Here are a few of them.

## ANTISTATIC FEATURE

Build-up of static electricity can occur as a result of constant rubbing of the ball against the PTFE seats. This can be a potential fire hazard, especially while handling inflammable fluids. All AIL Ball Valves are provided with built-in antistatic design features. In general, this is achieved through 35% Carbon-filled PTFE stem seals and Graphite gland packings to provide electrical continuity between the body and the stem / ball, discharging any build-up of static charge. In addition, spring-loaded plungers are provided between the stem and the ball in single-piece and two-piece reduced bore (80mm and above) and full bore (40mm and above) valves. Depending on the choice of seals, the designs also provide for additional spring-loaded plungers between the stem and the body for full mechanical antistatic capability.

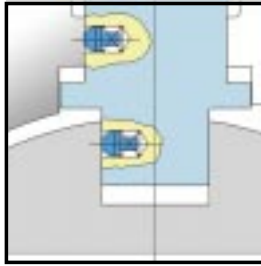

## MOULDED PTFE SEATS WITH SLOTS

PTFE seats are manufactured from moulded PTFE for a better grain structure compared to other methods of manufacture. Slots are provided in the seats to relieve the pressure past the upstream seat and prevent it from being forced against the ball. These features help lower operating torques, permit higher differential pressures and reduce wear, besides extending service life.



## MIRROR-FINISHED SS BALLS

The stainless steel balls are manufactured to very close sphericity tolerances and are mirror-finished. This results in bubble-tight sealing and considerably reduced operating torque.

## BLOW-OUT PROOF STEM

All AIL Ball Valves have a bottom-entry stem design which features stem insertion from inside the body. An integral shoulder on the stem sits against the shoulder in the body, giving it blow-out proof integrity. The higher the line pressure, the tighter the seal. This design offers safety features superior to top-entry stem design where the line pressure works to break the stem seating (see illustration for typical three-piece design).

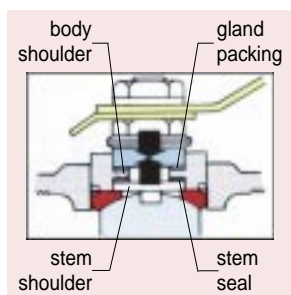

## LEAK TIGHT STEM SEALING

The stem seal package consists of one or two stem seals and one or a series of gland packing rings, depending on valve size. In smaller sizes of up to 50mm, a pair of Belleville washers acts as a spring to compensate for wear and thermal expansion. On larger valves, the deep stuffing box with additional packing provides resilience.

## FIRE-SAFE FEATURE

AIL fire-safe design valves feature a secondary metal-to-metal seat which renders the valve fire-safe. An integral metal lip in the body and the configuration of the soft seat are designed to prevent the softening downstream seat from being forced into the port in the event of a fire. When the seat is totally sublimated in a fire, the ball moves and rests against the lip, forming a metal-to-metal seat, thus ensuring leak-tightness. End connectors or inserts have spigoted ends to ensure concentricity and correct alignment of the ball.

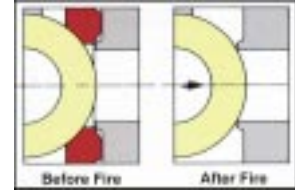

## VALVE OPERATION

As a standard, AIL Ball Valves are supplied with hand levers or gear units, depending on the valve size. The valves are also suitable for automation using either electric or pneumatic actuators. The AIL Series 90 Pneumatic Actuator is optimally designed for use with AIL Ball Valves, and is widely used to automate valves in diverse applications.



## WIDE VARIETY OF SEATS AND BODY SEALS

AIL Ball Valves are available with a wide variety of seat and seal material combinations to suit specific needs of customers. For details, refer to tables on inside rear cover page.

## CAVITY PRESSURE RELIEF

AIL's range of two-piece full bore valves come with a built-in cavity relief seat design. This feature prevents overpressure in the ball cavity due to thermal expansion of the line fluid, and finds use in applications involving volatile line fluids. In principle, when cavity pressure builds up and reaches a certain magnitude, it causes the seat lip to move away from the ball relieving the pressure. Once the pressure has relieved the seat lip returns until the pressure builds up again. In the case of single-piece and three-piece valves, and in two-piece regular bore valves, cavity relief can be provided on request by incorporating an upstream relief hole in the ball. All trunnion mounted ball valves have built-in cavity relief seat design. All valves have a hole connecting the ball port and the body cavity to prevent build-up of trapped cavity pressure when the valve is in open position.

## ACTUATOR MOUNTING FLANGE

All single-piece and two-piece valves are supplied with an integral actuator mounting flange with drilled and tapped holes suitable for mounting pneumatic actuators. The flange conforms to ISO 5211 for full bore valves and to AIL's manufacturing standard for reduced bore valves.

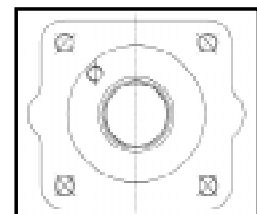

# Reduced Bore Ball Valves

## Three-piece design

### A44 - Standard series

This 3-piece Ball Valve is the most easily on-line maintainable in its class. By removing three body connector bolts and loosening the fourth, the body can be swung away using the fourth bolt as the fulcrum, to carry out any installation or maintenance operation on the valve, thus reducing downtime. This valve can be offered in a wide variety of body and seat combinations.

### AF44 - Fire-safe series

This 3-piece fire-safe design Ball Valve features a secondary metal seat which renders the valve fire-safe. When the seat is totally sublimated in a fire, the ball moves and rests against the lip, forming a metal-to-metal seat, thus ensuring leak-tightness.

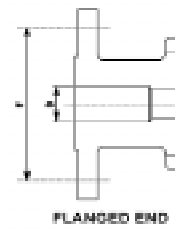
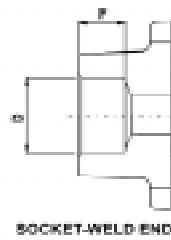
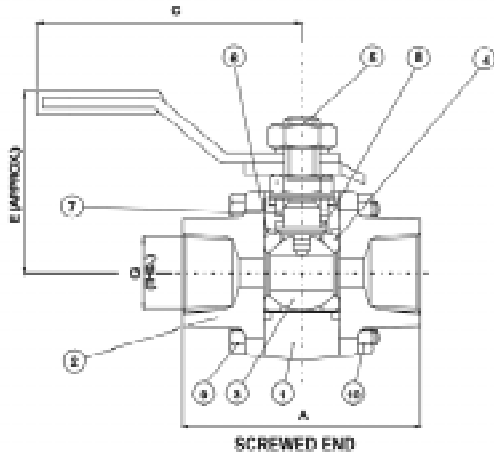

### Dimensional Details

*Screwed/Socket-weld end (in mm, unless specified)*

Valve Size	A	C	D	E	F	G	Approx. Weight (kg)
8	65	122	14.6 / 14.2	45	9.7	1/4"	0.6
10	65	122	18.0 / 17.6	45	9.7	3/8"	0.6
15	67	122	22.2 / 21.8	45	9.7	1/2"	0.6
20	73	122	27.6 / 27.1	48	12.7	3/4"	0.8
25	95	149	34.3 / 33.8	59	12.7	1"	1.6
32	107	149	43.1 / 42.7	65	12.7	1 1/4"	2.5
40	116	181	49.2 / 48.7	75	12.7	1 1/2"	3.3
50	128	181	61.7 / 61.1	80	15.9	2"	4.1



### Dimensional Details

*Flanged end (in mm, unless specified)*

Valve Size	C	D	E	Class 150			Class 300			Class 600			Approx. Weight (kg)		
				A	F	G	A	F	G	A	F	G	Cl. 150	Cl. 300	Cl. 600
15	152	12.7	90	108	89	11.1	140	96	15	165	96	22	1.8	2.2	4.5
20	152	19.1	98	117	99	12.2	153	118	17	191	118	24	2.3	3.2	6.3
25	177	25.4	102	127	108	11.1	165	124	19	216	124	26	3.1	4.5	9.1
40	202	38.1	121	165	127	14.3	191	156	22	241	156	30	6.4	8.7	15.4
50	202	50.8	126	178	154	15.9	216	165	23	292	165	33	9.0	10.8	21.6

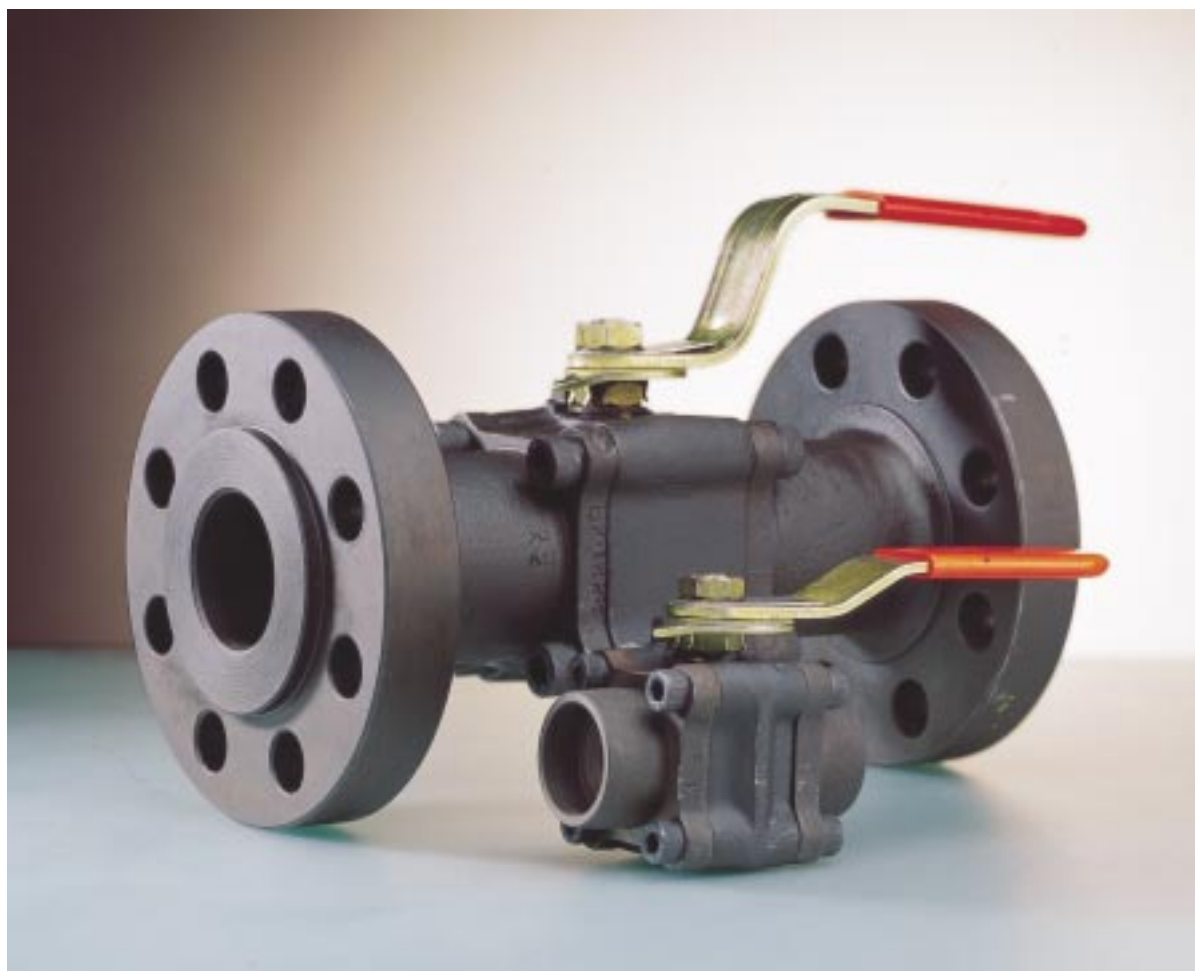

Material Specification		A44		AF44	
Sl. No.	Part	Carbon Steel	Stainless Steel	Carbon Steel	Stainless Steel
1	Body & Body Connector	ASTM A105 or ASTM A216 Gr. WCB	ASTM A351 Gr. CF8M	ASTM A105	ASTM A351 Gr. CF8M
2	Ball	ASTM A351 Gr. CF 8M		ASTM A351 Gr. CF 8M	
3	Seat	PTFE		PTFE	
4	Stem	AISI 316		AISI 316	
5	Body Seal	PTFE		Graphite	
6	Gland Packing	35% Carbon-filled PTFE		Graphite	
7	Stem Seal	35% Carbon-filled PTFE		35% Carbon-filled PTFE	
	Catalogue No.	A44-46-T-BT*	A44-66-T-BT*	AF44-46-T-BT*	AF44-66-T-BT*

\* AT (Screwed NPT) / BT (Screwed BSPT) / CT (Socket-weld) or FL150 / FL300 / FL600

For other materials of construction, refer to tables on inside rear cover page.

### Specifications

Max. cold working pressure	69kg/cm <sup>2</sup> for screwed/socket-weld end valves with PTFE seat 103kg/cm <sup>2</sup> for screwed/socket-weld end valves with polyfill seat As per flange rating for flanged valves
Valve design	BS 5159 for A44 Series BS 5351 for AF44 Series
Fire Test (for <b>AF44</b> )	API 607 4th edition
Testing	API 598 for flanged valves
Face-to-face dimensions	ASME B16.10 for flanged valves and AIL Standard for screwed/socket-weld end valves

### Pressure Testing

#### Test pressures

	Ends	kg/cm <sup>2</sup>	(psi)
<b>Shell</b>	Screwed/Socket weld (air)	5.6	(80)
	Flanged 150 (hydrostatic)	31.5	(450)
	Flanged 300 (hydrostatic)	79.0	(1125)
	Flanged 600 (hydrostatic)	154.0	(2225)
<b>Seat</b>	All valves (air)	5.6	(80)

**NOTE** Pressure testing as per BS 6755 available on special request.

Shell hydrostatic test can be done for screwed and socket-weld end valves on special request.

Shell hydrostatic test can be done as per Class 800 rating for both versions on special request.

# Reduced Bore Ball Valves

## Single-piece and two-piece design

### AF51, AF52 - Fire-safe series

These single-piece Ball Valves are high performance valves which come with a one-piece integrally flanged body, in sizes of up to 200mm. This design offers the unique advantage of eliminating the possibility of external leakage to the atmosphere through bolted body joints. These environment-friendly and high-integrity valves are preferred in critical applications where the media is expensive, volatile or toxic, and where external leakage or wastage is unacceptable.

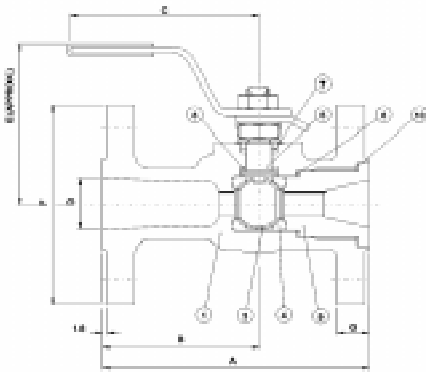

### AF55, AF56 - Fire-safe series

These 2-piece design fire-safe design Ball Valves complement the single-piece design in 250mm size.

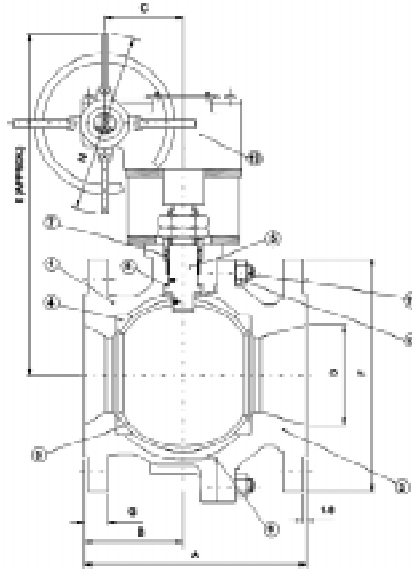

#### Dimensional Details

Flanged end (in mm, unless specified)

#### AF51 (Class 150)

Valve Size	A	B	C	D	E	F	G	Approx. Weight (kg)
15	108	62	152	12.7	89	89	11.5	1.5
20	117	68	152	19.1	91	99	11.5	2.0
25	127	70	177	25.4	103	108	11.5	3.0
40	165	78	202	38.1	118	127	14.5	5.0
50	178	107	202	50.8	131	154	16.0	8.1
80	203	120	546	76.2	169	191	19.5	17.0
100	229	130	546	102.0	182	229	24.0	27.8
150	267	138	762	150.8	275	280	25.4	47.0
200	292	148	-	203.0	-	343	28.4	115.0

#### AF52 (Class 300)

Valve Size	A	B	C	D	E	F	G	Approx. Weight (kg)
15	140	94	152	12.7	89	96	15	2.2
20	152	103	152	19.1	91	118	16	3.2
25	165	108	177	25.4	103	124	18	4.5
40	190	116	202	38.1	118	156	21	8.7
50	216	145	202	50.8	131	165	22.5	10.8
80	283	199	546	76.2	169	210	29	24.1
100	305	206	546	102.0	182	254	32	37.5
150	403	274	762	150.8	275	318	37	67.0
200	419	275	-	203.0	-	381	41	167.0

#### AF55 (Class 150)

Valve Size	A	B	C	D	E	F	G	H	Approx. Weight (kg)
250	330	165	148	254	686	406	30.5	578	-

#### AF56 (Class 300)

Valve Size	A	B	C	D	E	F	G	H	Approx. Weight (kg)
250	457	229	148	254	686	445	48	578	-



Material Specification		AF51 / AF52 / AF55 / AF56	
Sl. No.	Part	Carbon Steel	Stainless Steel
1	Body	ASTM A216 Gr. WCB	ASTM A351 Gr. CF8M
2	Insert	ASTM A105 or ASTM A216 Gr. WCB	AISI 316 or ASTM A351 Gr. CF8M
3	Ball	ASTM A351 Gr. CF 8M	ASTM A351 Gr. CF8M
4	Seat	PTFE	PTFE
5	Stem	AISI 316	AISI 316
6	Body Seal	PTFE	PTFE
7	Gland Packing	Graphite	Graphite
8	Stem Seal	35% Carbon-filled PTFE	35% Carbon-filled PTFE
9	Insert Seal	15mm - 40mm, 200mm : Metal-to-metal 50mm - 150mm : Graphite	15mm - 40mm, 200mm : Metal-to-metal 50mm - 150mm : Graphite
	Catalogue No.	AF51-46-T**	AF51-66-T**

**\*\* AF51 (Class 150) / AF55 (Class 150) / AF52 (Class 300) / AF56 (Class 300)**  
 For other materials of construction, refer to tables on inside rear cover page.

### Specifications

Valve design	BS 5351
Fire test	API 607, 4th edition
Pressure testing	API 598 (testing as per BS 6755 Part I on special request)
Face-to-face dimensions	ASME B16.10
End flange dimensions	ASME B16.5 Class 150 RF and Class 300 RF

### Pressure Testing

<u>Test pressures</u>		kg/cm <sup>2</sup> (psi)
<u>Ends</u>		
<b>Shell</b>	Class 150 (hydrostatic)	31.5 (450)
	Class 300 (hydrostatic)	79.0 (1125)
<b>Seat</b>	Class 150 (air)	5.6 (80)
	Class 300 (air)	5.6 (80)

# Full Bore Ball Valves

## Three-piece design

### AB44 - Standard series

This 3-piece Ball Valve is the most easily on-line maintainable in its class. By removing three body connector bolts and loosening the fourth, the body can be swung away using the fourth bolt as the fulcrum, to carry out any installation or maintenance operation on the valve, thus reducing downtime. This valve can be offered in a wide variety of body and seat combinations.

### AFB44 - Fire-safe series

This 3-piece fire-safe design Ball Valve features a secondary metal seat which renders the valve fire-safe. When the seat is totally sublimated in a fire, the ball moves and rests against the lip, forming a metal-to-metal seat, thus ensuring leak-tightness.

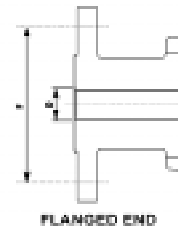
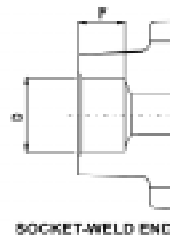
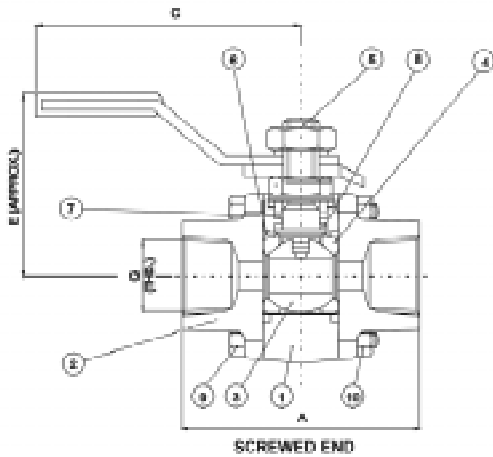

AB44 SEAT



AFB44 SEAT

### Dimensional Details

*Screwed/Socket-weld end (in mm, unless specified)*

Valve Size	A	C	D	E	F	G	Approx. Weight (kg)
15	73	122	22.2 / 21.8	48	9.7	1/2"	0.8
20	95	149	27.6 / 27.1	59	12.7	3/4"	1.6
25	116	181	34.3 / 33.8	75	12.7	1"	3.3
40	128	181	49.2 / 48.7	80	12.7	1 1/2"	4.1



### Dimensional Details

*Flanged end (in mm, unless specified)*

Valve Size	C	D	E	Class 150			Class 300			Class 600			Approx. Weight (kg)		
				A	F	G	A	F	G	A	F	G	Cl. 150	Cl. 300	Cl. 600
15	152	12.7	98	108	89	11.1	140	96	15	165	96	22	2.3	3.2	6.3
20	177	19.1	102	117	99	12.2	153	118	17	191	118	24	3.1	4.5	9.1
25	202	25.4	121	127	108	11.1	165	124	19	216	124	26	6.4	8.7	15.4
40	202	38.1	126	165	127	14.3	191	156	22	241	156	30	9.0	10.8	21.6





Material Specification		AB44		AFB44	
Sl. No.	Part	Carbon Steel	Stainless Steel	Carbon Steel	Stainless Steel
1	Body & Body Connector	ASTM A105 or ASTM A216 Gr. WCB	ASTM A351 Gr. CF8M	ASTM A105	ASTM A351 Gr. CF8M
2	Ball	ASTM A351 Gr. CF8M		ASTM A351 Gr. CF8M	
3	Seat	PTFE		PTFE	
4	Stem	AISI 316		AISI 316	
5	Body Seal	PTFE		Graphite	
6	Gland Packing	35% Carbon-filled PTFE		Graphite	
7	Stem Seal	35% Carbon-filled PTFE		35% Carbon-filled PTFE	
	Catalogue No.	AB44-46-T-BT*	AB44-66-T-BT*	AFB44-46-T-BT*	AFB44-66-T-BT*

\* AT (Screwed NPT) / BT (Screwed BSPT) / CT (Socket-weld) or FL150 / FL300 / FL600

For other materials of construction, refer to tables on inside rear cover page.

### Specifications

Max. cold working pressure	69kg/cm <sup>2</sup> for screwed/socket-weld end valves with PTFE seat 103kg/cm <sup>2</sup> for screwed/socket-weld end valves with polyfill seat As per flange rating for flanged valves
Valve design	BS 5159 for A44 Series BS 5351 for AF44 Series
Fire Test (for <b>AFB44</b> )	API 607 4th edition
Testing	API 598 for flanged valves
Face-to-face dimensions	ASME B16.10 for flanged valves and AIL Standard for screwed/socket-weld end valves

### Pressure Testing

#### Test pressures

	Ends	kg/cm <sup>2</sup> (psi)
<b>Shell</b>	Scr./Socket weld (air)	5.6 (80)
	Flanged 150 (hydrostatic)	31.5 (450)
	Flanged 300 (hydrostatic)	79.0 (1125)
	Flanged 600 (hydrostatic)	154.0 (2225)
<b>Seat</b>	All valves (air)	5.6 (80)

**NOTE** Pressure testing as per BS 6755 available on special request.

Shell hydrostatic test can be done for screwed and socket-weld end valves on special request.

Shell hydrostatic test can be done as per Class 800 rating for both versions on special request.

# Full Bore Ball Valves

## Single-piece / Two-piece design

### F15 Fire-safe Series (Class 150)

### F30 Fire-safe Series (Class 300)

These high performance full bore ball valves come in single-piece design (in sizes of 15 - 40mm) as well as in two-piece design (in sizes of 50 - 200mm). Advanced features such as fire safety, antistatic capability, cavity relief and blow-out proof stem are built into these valves. They are supplied with an integral actuator mounting flange with drilled and tapped holes conforming to ISO 5211.

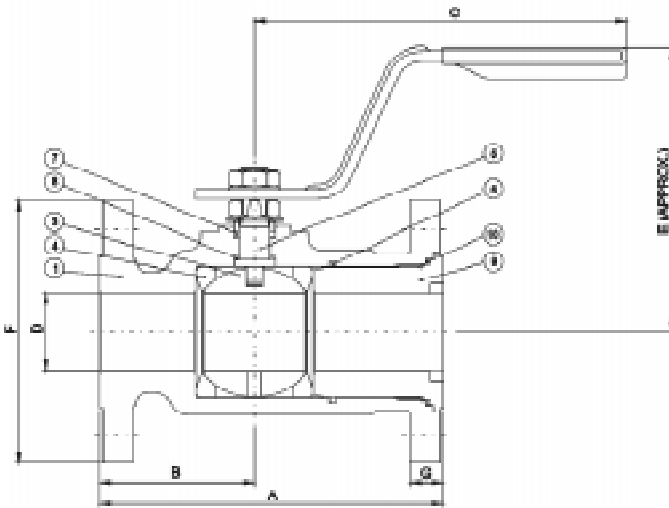
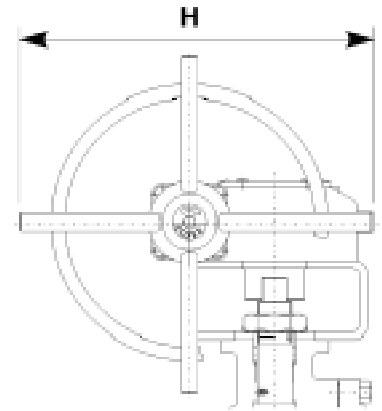

15mm - 40mm

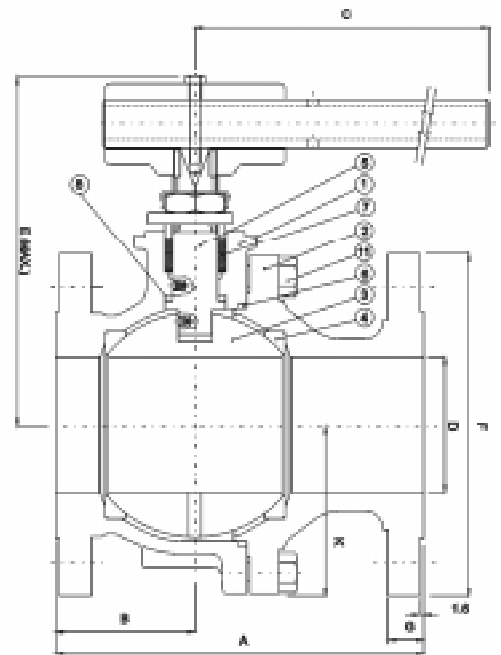

50mm - 200mm

#### Dimensional Details

(in mm, unless specified)

#### F15 (Class 150)

Valve Size	A	B	C	D	E	H	Approx. Weight (kg)
15	108	46	163	12.7	97	-	1.8
20	117	50	168	19.1	118	-	2.5
25	127	56	168	25.4	123	-	3.4
40	165	75	193	38.1	139	-	8.5
50	178	84	193	50.8	150	-	12.2
65	191	77	402	64.1	190	-	18.5
80	203	99	256	76.2	155	-	23.0
100	229	108	402	101.6	196	-	42.6
150	394	179	1004	150.8	315	-	90.0
200	457	206	-	203.0	690	578	170.0

#### F30 (Class 300)

Valve Size	A	B	C	D	E	H	Approx. Weight (kg)
15	140	78	163	12.7	97	-	2.5
20	153	85	168	19.1	118	-	3.8
25	165	94	168	25.4	123	-	5.1
40	191	100	193	38.1	139	-	9.5
50	216	84	193	50.8	150	-	15.2
65	241	83	402	64.1	190	-	26.0
80	283	99	402	76.2	205	-	32.6
100	305	122	610	101.6	240	-	59.0
150	403	179	-	150.8	645	578	121.0
200	502	231	-	203.0	745	578	210.0



Material Specification		F15 / F30	
Sl. No.	Part	Carbon Steel	Stainless Steel
1	Body	ASTM A216 Gr. WCB	ASTM A351 Gr. CF8M
2	Body Connector	ASTM A216 Gr. WCB	ASTM A351 Gr. CF8M
3	Ball	ASTM A351 Gr. CF 8M	ASTM A351 Gr. CF8M
4	Seat	PTFE	PTFE
5	Stem	AISI 316	AISI 316
6	Body Seal	Graphite	Graphite
7	Gland Packing	Graphite	Graphite
8	Stem Seal	25% Glass-filled PTFE	25% Glass-filled PTFE
9	Insert	ASTM A105 / ASTM A216 Gr. WCB / IS1875 Cl2	AISI 316 or ASTM A351 Gr. CF8M
10	Insert gasket	Graphite	Graphite
	Catalogue No.	F15-44-T**	F15-66-T**

### F15 (Class 150) / F30 (Class 300)

Single-piece valves up to 40mm ; 2-piece valves from 50mm onwards.

### Specifications

Valve design	BS 5351
Fire test	API 607, 4th edition
Pressure testing	API 598 (testing as per BS 6755 Part I on special request)
Face-to-face dimensions	ASME B16.10 (compliance to BS 2080 can be offered on request)
End flange dimensions	ASME B16.5 Class 150 RF and Class 300 RF

### Pressure Testing

<u>Test pressures</u>		
	Ends	kg/cm <sup>2</sup> (psi)
<b>Shell</b>	Class 150 (hydrostatic)	31.5 (450)
	Class 300 (hydrostatic)	79.0 (1125)
<b>Seat</b>	Class 150 (air)	5.6 (80)
	Class 300 (air)	5.6 (80)

# Special-purpose Ball Valves

## for demanding applications

### VALVES FOR STEAM SERVICES (IBR CERTIFIED)

#### AW44 - ENERGYSISER

This valve is specially designed for on/off steam applications and conserves energy by providing bubble-tight sealing in steam services. The valves are IBR certified.

Material Specification	AW44
<i>Part</i>	<i>Carbon Steel version only</i>
Body & Body Connector	ASTM A105 or ASTM A216 Gr. WCB
Ball	ASTM A351 Gr. CF8M
Seat	Polyfill
Stem	AISI 316
Body Seal	Graphite
Gland Packing	35% Carbon-filled PTFE
Stem Seal	35% Carbon-filled PTFE
Catalogue No.	AW44-46-T-BT*

\* AT (Screwed NPT) / BT (Screwed BSPT) / CT (Socket-weld) / FL150 / FL300

#### Specifications

Max. cold working pressure	103kg/cm <sup>2</sup> for screwed/socket-weld end valves As per flange rating for flanged valves
Valve design	BS 5159
Testing	API 598
Face-to-face dimensions	AIL Standard

#### Pressure Testing

##### Test pressures

	Ends	kg/cm <sup>2</sup>	(psi)
<b>Shell</b>	(hydrostatic)	156.5	(2275)
<b>Seat</b>	(air)	5.6	(80)



#### OTHER VALVES

The full range of reduced and full-bore valves are available with special designs for steam services and can be supplied with IBR certification. In general, these valves will have seats of polyfill and body seals of graphite. Pressure ratings will be as per flange ratings in flanged valves and 103kg/cm<sup>2</sup> for screwed/socket-weld end valves.

#### NOTE :

For dimensions of AW44 valves refer to table on A44 series. For other valves, refer to respective tables.

### VALVES FOR CRYOGENIC SERVICE

#### C44

The C44 series Cryogenic Valve is designed for low temperature services down to -196°C. Typical applications are LNG storage/distribution, terminal unloading stations, liquid Nitrogen and liquid Oxygen lines. The valves incorporate exclusive features such as :

- **Positive ball cavity relief** - an upstream relief hole in the ball to prevent over pressure due to thermal expansion
- **Effective stem extensions** - conformance to standard international practices ; selection of wall thickness and lengths to keep heat transfer down, packing frost-free, operational torques low and actuators well supported
- **Superior stem design** - a one-piece stem with special stem seals to ensure a zero-leak stem and low operating torque
- **High performance sealing** - special polyfill seats and body seals to ensure bubble-tight shutoff and zero body leakage
- **Ease of installation** - three-piece construction to facilitate easy installation and maintenance
- **Flexibility** - a variety of end connections such as screwed end, socket-weld end and extension nipples

**NOTE :** For general dimensions, refer to table on A44 series. AIL's single-piece valves are also available for cryogenic service with and without stem extensions.



## VALVES FOR HIGH PRESSURE SERVICE

### 5HP44

The AIL Series 5HP-44 Ball Valve has been specially developed to meet the industry's requirement of a safe and reliable shut-off valve for high-pressure applications. This valve incorporates a number of product features like high-pressure seals, thicker flanges on the body connectors, high-tensile bolting, special acetal resin seats, high-strength stem and high-pressure integrity gland assembly.

Material Specification	5HP44
<i>Part</i>	<i>Carbon Steel version only</i>
Body	ASTM A105/A216 Gr. WCB
Body Connector	ASTM A105/A216 Gr. WCB / IS 1875 CI 2
Ball	ASTM A351 Gr. CF8M
Seat	Acetal Resin
Stem	ASTM A564 Type 630
Body Seal	Nitrile Rubber
Gland Packing	15% glass-filled PTFE
Stem Seal	Nylon
Catalogue No.	5HP44-46-D-BT*

\* AT (Screwed NPT) / BT (Screwed BSPT) / CT (Socket-weld)



#### Specifications

Max. cold working pressure	352kg/cm <sup>2</sup> for liquids 210kg/cm <sup>2</sup> for gases (15-25mm) 168kg/cm <sup>2</sup> for gases (40-50mm)
Valve design	BS 5159
Testing	API 598
Face-to-face dimensions	AIL Standard

#### Pressure Testing

##### Test pressures

	Ends	kg/cm <sup>2</sup>	(psi)
Shell	(hydrostatic)	527.0	(7500)
Seat	(air)	5.6	(80)

#### Dimensional Details (in mm, unless specified)

Valve Size	A		C		D	E		F
	Scr. end	S/W end	Scr. end	S/W end		Scr. end	S/W end	
15	77.8	85	122	122	22.2 / 21.8	47	50	9.7
20	85	108	122	149	27.6 / 27.2	50	60	12.7
25	108	131	149	256	34.3 / 33.9	60	76	12.7
40	131	142	256	256	49.2 / 48.8	76	81	12.7
50	142	142	256	256	61.7 / 61.2	81	81	16.0

The standard 5HP44 valve is a reduced bore valve.

## MULTI-PORT BALL VALVES

**AD13 - 'T' Port Diverter Valve**

**AD14 - 'L' Port Diverter Valve**

**AT13 - 'T' Port Three-way Valve**

**AT14 - 'L' Port Three-way Valve**

The Diverter Valve is designed to divert media from the bottom inlet port to either of the two outlet ports. The Three-way Valve, also known as a Mixer Valve, permits use of any port as inlet.

#### NOTE :

Available in screwed and socket-weld designs. For material specifications and general dimensions, refer to table on A44 series.



## VALVES FOR HIGH TEMPERATURE SERVICE

These are high-durability ball valves for superheated steam and high temperature applications, with the following features :

- Ability to handle high pressure and temperature shock
- Ability to withstand high pressure drops
- Ability to resist abrasion and wear
- Services up to 340°C and 100kg/cm<sup>2</sup> pressure

**NOTE :** Available in single-piece and three-piece designs. For general dimensions, refer to respective tables.

The metal-seated versions have a graphite impregnated alloy stainless steel seat with integral graphite seat seal. These are suitable for conditions up to 340°C and 70kg/cm<sup>2</sup>. The stainless steel ball is ENP coated to make the surface harder. The resilient seated versions feature PEEK seats which handle conditions up to 280°C and 100kg/cm<sup>2</sup>.

# Trunnion Mounted Ball Valves (TMBV)

**TR15, TR30 Reduced Bore Series (Class 150 and Class 300)**  
**TF15, TF30 Full Bore Series (Class 150 and Class 300)**

The AIL **Trunnion Mounted Ball Valve** is the preferred choice of ball valve in higher sizes and pressure ratings, and in critical process applications requiring special capabilities. In this design, sealing takes place by allowing the seat to move towards the ball along the flow axis, which leads to lower operating torques over other types of valves. The valves have advanced design features such as a built-in cavity relief mechanism, compact internal trunnion holder, and intrinsic double block and bleed facility. The valves are of two-piece design, bolted at the body connection joint and with flanged or butt weld ends, and are available in both reduced bore and full bore designs.

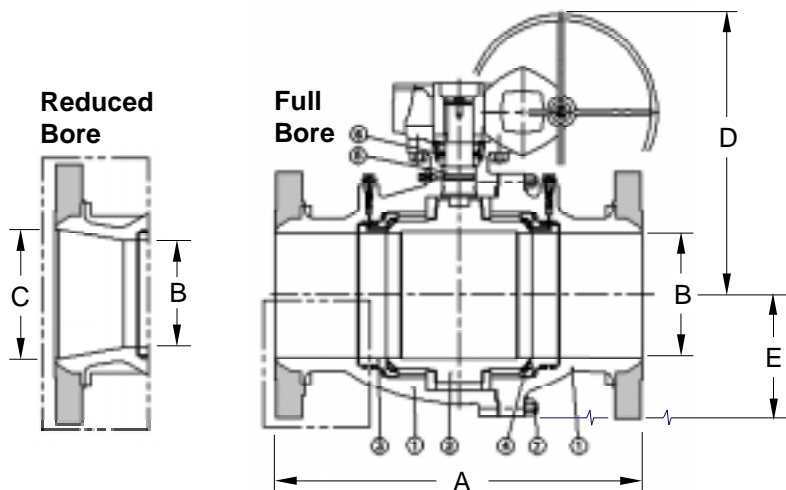

**Material Specification** **TR15 / TR30 / TF15 / TF30**

Sl. No.	Part	Carbon Steel
1	Body and Body Connector	ASTM A216 Gr. WCB
2	Ball	ASTM A216 Gr. WCB, ENP coated
3	Seat	PTFE
4	Seat Housing	ASTM A395, PTFE coated
5	Stem	AISI 410
6	Stem Seal	Graphite
7	Bolting	ASTM A193 B7 / ASTM A194 2H
8	"O" Rings	Nitrile Rubber
	Catalogue No.	TR15-46-T**

**TR15 / TF15 (Class 150) / TR30 / TF30 (Class 300)**

Alternate materials like SS and Alloy Steel are available.

Special seat materials available on request. For details, refer Ordering Information.

**Specifications**

Valve design	Soft-seated : API 6D / BS 5351
Pressure testing	API 6D / ASME B16.34
Face-to-face dimension	ASME B16.10
End flanges	ASME B16.5 Class 150 and Class 300 RF
Butt-weld ends	ASME B16.25 (schedule as per customer requirement)

**Pressure Testing**

<b>Test pressures</b>		
	<b>Ends</b>	<b>kg/cm<sup>2</sup> (psi)</b>
<b>Shell</b>	Class 150 (hydrostatic)	31.5 (450)
	Class 300 (hydrostatic)	79.0 (1125)
<b>Seat</b>	Class 150 (air)	5.6 (80)
	Class 300 (air)	5.6 (80)

## Seat Details

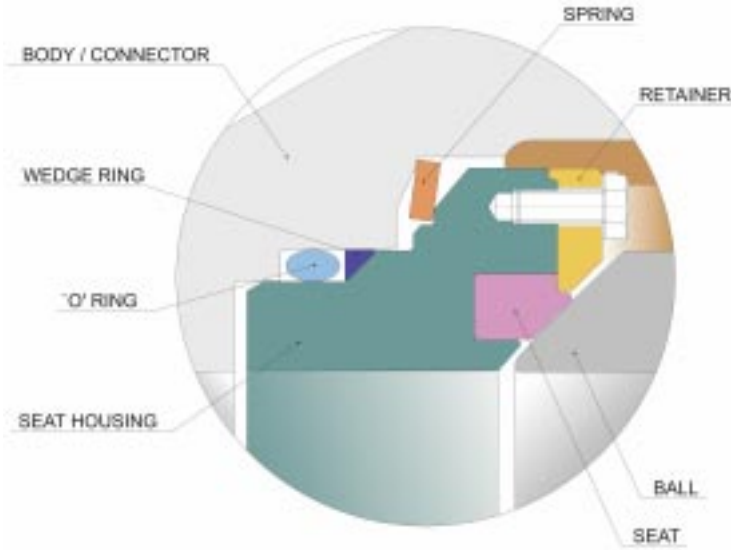

### BENEFITS

- Proven Double Block and Bleed feature**  
 Argus Trunnion Mounted Ball Valves are designed for upstream sealing, so that the double block and bleed feature is automatically built in. The feature enables on-line affirmation of proper seat sealing.

- Enhanced stem seal life, low wear on seats**  
 The reaction generated by the line fluid load on the ball is absorbed by the trunnion bearings and directly transmitted to the valve body. The valve stem is hence free from any bending load which leads to reduced stem friction torques and enhanced stem seal life.

The seat rings are allowed to move in the flow axis against a fixed ball so that the line pressure assists in pressing the spring-loaded upstream seat against the ball. Thus, the operating torque and wear on the seats is relatively low, enhancing seat life.

- High-integrity seat and stem sealing systems**  
 The soft-seated valve designs use PTFE or other suitable elastomers as the **primary seating material**. These seats are designed to ensure full leak-tightness. Both upstream and downstream sealing are assisted by seat-loading mechanisms consisting of retainer, spring, 'O' ring and wedge ring, which continuously press the seats against the ball.

- Automatic cavity relief feature**  
 The seat design of Argus T-Series Trunnion mounted Ball Valves has a built-in automatic cavity relief mechanism. In the event of excessive pressure build-up inside the cavity, the springs that keep the seats pressed to the ball are pressed back by the seat, allowing the release of excessive pressure. This eliminates the need for having external cavity relief assemblies.

- Blowout-proof stem**

- Internal trunnion holder**  
 The internal trunnion/bearing holders in the valve eliminate many drawbacks arising from valve designs that feature external trunnion/bearing holders.

- Fire-safe by design, to meet requirement of API 607 for soft seated valves**

- Compliance to NACE (optional)**

### DIMENSIONAL DETAILS - FULL BORE VALVES (in mm)

Valve Size	A				B
	Class 150		Class 300		Class 150/300
	Flanged	Butt-weld	Flanged	Butt-weld	Flngd / Butt-wld
100 (4")	229	305	305	305	100.0
150 (6")	394	457	403	457	150.8
200 (8")	457	521	502	521	201.6
250 (10")	533	559	568	559	252.4
300 (12")	610	635	648	635	303.2
350 (14")	686	762	762	762	335.0
400 (16")	762	838	838	838	385.8
450 (18")	864	914	914	914	436.6
500 (20")	914	991	991	991	487.4

### DIMENSIONAL DETAILS - REDUCED BORE VALVES (in mm)

Valve Size	A				B	C	D		E
	Class 150		Class 300		Class 150/300	Class 150/300	Class 150	Class 300	Class 150/300
	Flanged	Butt-weld	Flanged	Butt-weld	Flngd / B. wld	Flngd / B. wld	Flngd / B. wld	Flngd / B. wld	Flngd / B. wld
100 (4"x3")	229	305	305	305	75	100	360	360	130
150 (6"x4")	394	457	403	457	100	150.8	450	450	165
200 (8"x6")	457	521	502	521	150.8	201.6	520	570	220
250 (10"x8")	533	559	568	559	201.6	252.4	610	610	255
300 (12"x10")	610	635	648	635	252.4	303.2	665	665	300
350 (14"x10")	686	762	762	762	252.4	335	810	910	340
400 (16"x12")	762	838	838	838	303.2	385.8	910	1015	370
450 (18"x14")	864	914	914	914	335	436.6	1050	1065	420
500 (20"x16")	914	991	991	991	385.8	487.4	1120	1140	460

# Pneumatic Actuators

## Series 90 Double Acting and Spring Return types

**AIL Pneumatic Actuators** are among the widely used actuators today and are in service in diverse industries such as pharmaceutical, chemical, petrochemical, food and nuclear power. Compactness, reliability, low maintenance needs and ruggedness combine to make these actuators the best choice for use with ball valves.

### Spring Return (SR) type Actuator



**Double Acting (DA) type Actuator**

### SERIES 90 ACTUATOR

The AIL Series 90 Actuator optimised for use with AIL ball valves for safe remote plant automation. Offered in two options - **Double Acting (DA)** and **Spring Return (SR)** - this actuator incorporates a rack-and-pinion mechanism to ensure positive engagement and a constant torque output throughout the entire cycle.

### Material Specifications

Description	Material
Housing/Piston and End Cap	Aluminium Alloy
Pinnion	Steel
Seals	Nitrile Elastomer
Retention Spring Wire	Stainless Steel
Pinnion Bush	Nylon or filled PTFE
Springs	Spring Steel

### Features

**Housing** : Precision-extruded or cast, to offer a lightweight, compact body with sound pressure porting. Anodised to provide resistance to wear and corrosion.

**Piston** : Rugged one-piece piston with integral rack to ensure positive engagement with the pinnion. Anodised to provide resistance to wear and corrosion.

**Pinnion** : Surface-tested with low-friction coating for smooth operation.

**End Cover** : Powder-coated for resistance to corrosion, with a single SS spring wire for positive clamping.

**Pinnion Bush** : Self-lubricated for low friction and smooth operation.

### Technical Specifications

Mounting standard	ISO 5211
Pinnion top	NAMUR
Media	Filtered and lubricated dry air or inert gas
Temperature range	-10°C to +80°C
Operating pressure range	<b>Double Acting</b> 2.1kg/cm <sup>2</sup> to 8.4kg/cm <sup>2</sup> (30psi to 120psi) <b>Spring Return</b> 2.1kg/cm <sup>2</sup> to 7.0kg/cm <sup>2</sup> (30psi to 100psi)
Rotation	Open - counterclockwise Close - clockwise

### Ordering Information

**Valve Details** : Break-open and closing torques, stem top and mounting flange details.

**Service conditions** : Line fluid, temperature, differential pressure and frequency of operation.

**Actuator data** : **Double Acting or Spring Return** ; operating media, operating pressure, media temperature (max) and operating time required.

**Solenoid Valve** : Type, size, material, power supply ; enclosure (weather-proof / flame-proof) with relevant standards.

**Limit Switch** : Nos., Switch type (1NO+1NC or 2NO+2NC), power supply (DC/AC), electrical rating (VA or watts), enclosure (weather-proof / flame-proof) with relevant standards.

**Other accessories** : Manual override, quick exhaust valve, accumulator, air filter regulator etc.



# Selection Guide

Use the charts below to select the appropriate model of actuator. The valve size (X-axis), the valve operating pressure (Y-axis) and the actuator air supply pressure (80psi or 60psi indicated in the chart title) together determine the actuator selection. For selection of actuators for TMBV or for 5HP44 valves, please contact ALL.

## DOUBLE ACTING RANGE

### Reduced Bore Valves 5.6kg/cm<sup>2</sup> (80psi)

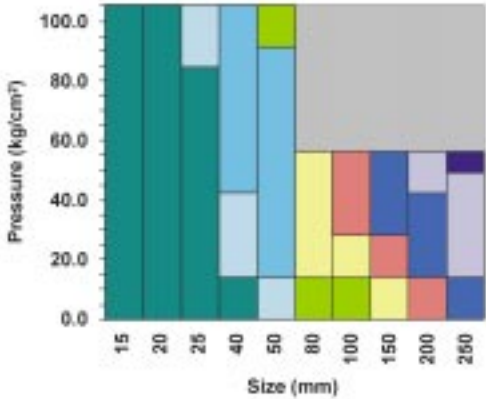

### Full Bore Valves 5.6kg/cm<sup>2</sup> (80psi)

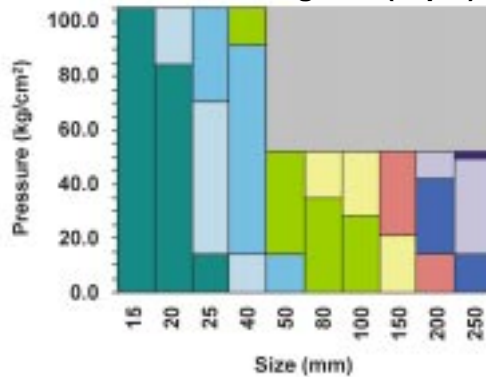

### Reduced Bore Valves 4.2kg/cm<sup>2</sup> (60psi)

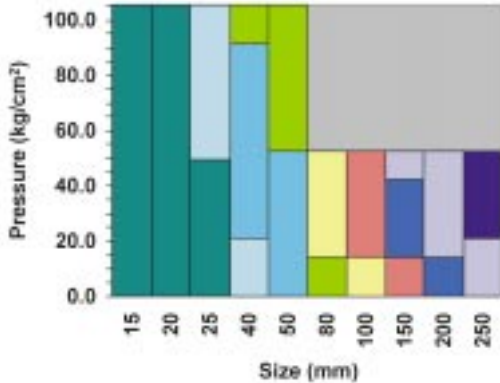

### Full Bore Valves 4.2kg/cm<sup>2</sup> (60psi)

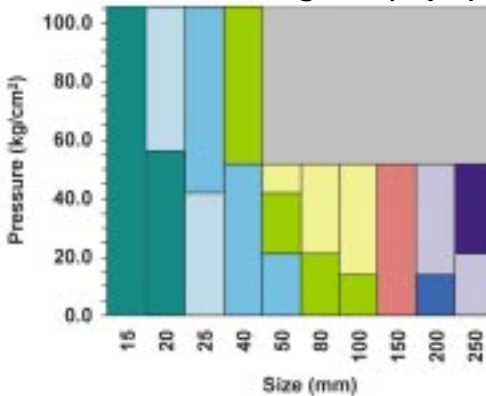

- 05DA
- 20DA
- 50DA
- 90DA
- 110DA
- 10DA
- 30DA
- 70DA
- 100DA

## SPRING RETURN RANGE

### Reduced Bore Valves 5.6kg/cm<sup>2</sup> (80psi)

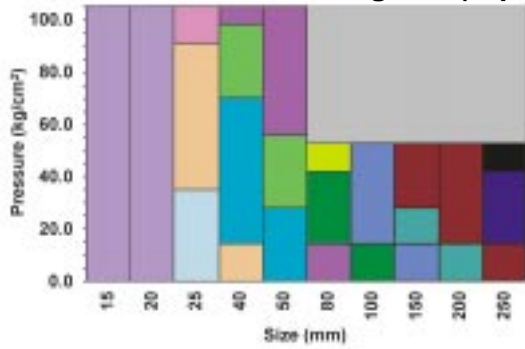

### Full Bore Valves 5.6kg/cm<sup>2</sup> (80psi)

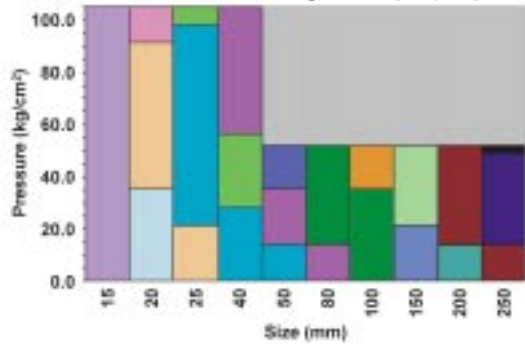

### Reduced Bore Valves 4.2kg/cm<sup>2</sup> (60psi)

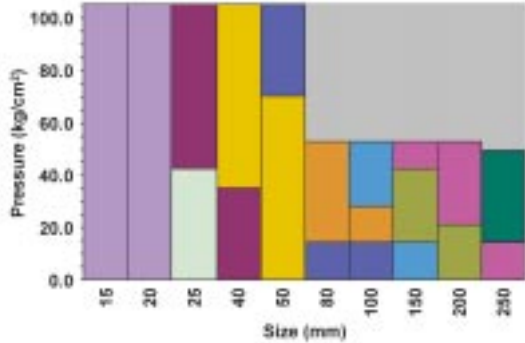

### Full Bore Valves 4.2kg/cm<sup>2</sup> (60psi)

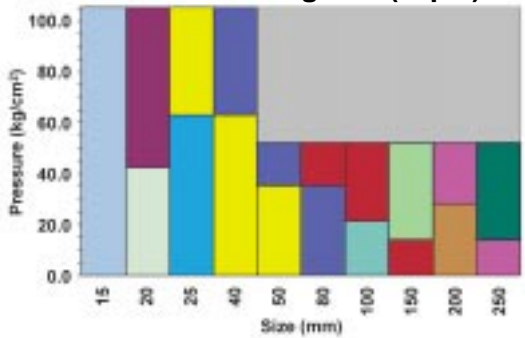

- 05SR50
- 20SR60
- 30SR80
- 70SR70
- 100SR70
- 05SR60
- 20SR70
- 50SR60
- 70SR80
- 100SR80
- 05SR80
- 20SR80
- 50SR70
- 90SR60
- 110SR60
- 10SR50
- 30SR50
- 50SR80
- 90SR70
- 110SR80
- 10SR80
- 30SR60
- 70SR50
- 90SR80
- 120SR70
- 20SR50
- 30SR70
- 70SR60
- 100SR60
- 120SR80

# Pressure-Temp. Graphs

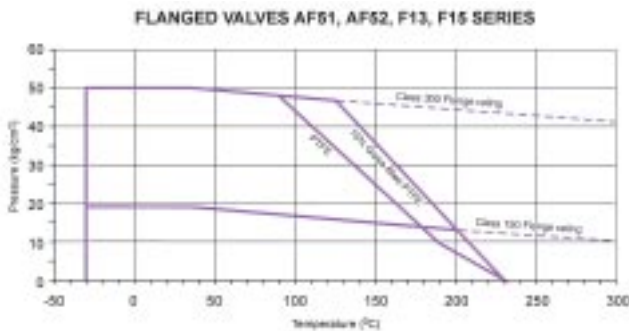
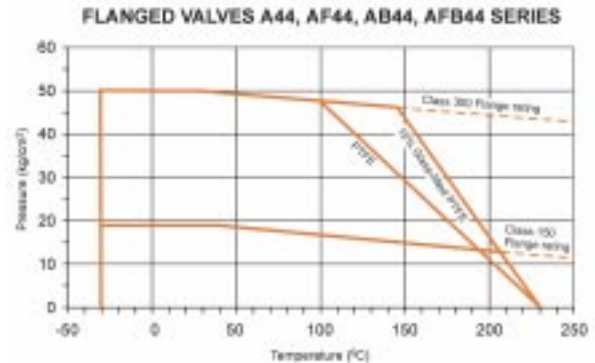
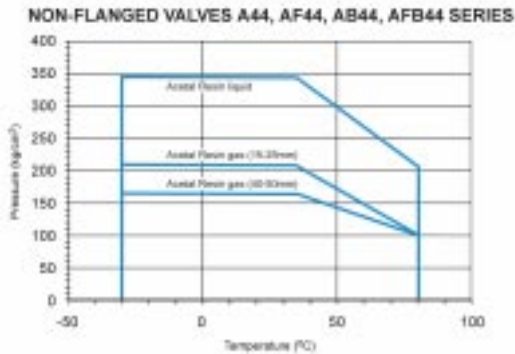
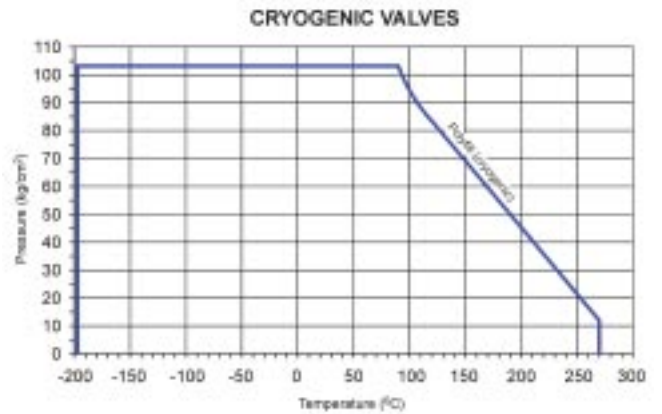
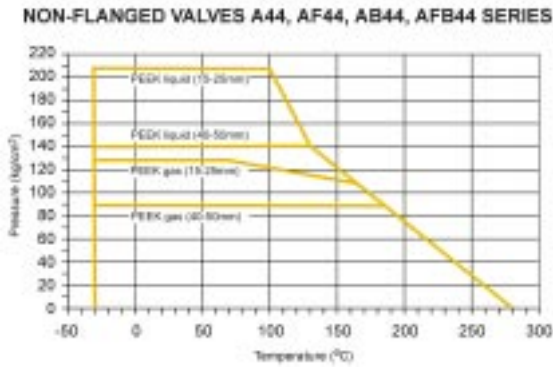
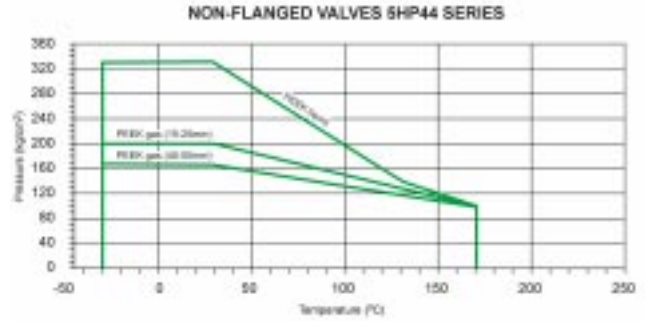
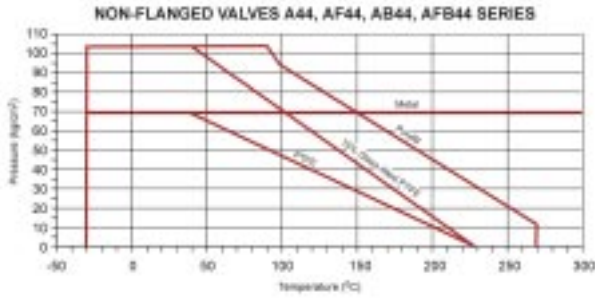

The information contained in this section is to be used only as a guide to the maximum temperature-pressure combination that the seat material can withstand.

Other factors such as process medium, material of construction of metal parts and design rating of the valve can also restrict overall valve performance.

## Flow Coefficients ( $K_v$ values)

Vlv. Size	15	20	25	32	40	50	65	80	100	150	200	250
Reduced bore	7	10	28	39	71	104	208	303	623	882	1557	2569
Full bore	33	61	95	199	303	433	675	1002	1832	4366	8077	16003

$K_v$  = flow coefficient in  $m^3/hr$

# Materials of construction

## BODY AND BODY CONNECTOR

Material	Specification
Carbon Steel	ASTM A105
Carbon Steel	ASTM A216 Gr. WCB
Stainless Steel	ASTM A351 Gr. CF8M
Stainless Steel	ASTM A351 Gr. CF8
Stainless Steel	ASTM A351 Gr. CF3M
Stainless Steel	ASTM A351 Gr. CF3
Alloy 20	ASTM A351 Gr. CN7M
LCB	ASTM A352 Gr. LCB

AIL Ball Valves can be supplied in a highly versatile range of body, seat and trim combinations to suit almost all types of services.

Details of certain common materials of construction are furnished here. For a more exhaustive list of available materials and for guidance on body/ball/seat material combinations, refer to Ordering Information on rear cover.

**NOTE :** Materials conforming to NACE standard, and for special services like Oxygen and Hydrogen can be supplied.

## TRIMS (CONSISTING OF BALL / STEM)

Material	Specification
Stainless Steel	ASTM A351 Gr. CF8M / AISI 316
Stainless Steel	ASTM A351 Gr. CF8 / AISI 304
Stainless Steel	ASTM A351 Gr. CF3M / AISI 316L
Stainless Steel	ASTM A351 Gr. CF3 / AISI 304L
13% Chromium Steel	ASTM A351 Gr. CA15 / AISI 410
Monel	
Hastelloy C	
Alloy 20	ASTM A351 Gr. CN7M
SG Iron	ASTM A395 PTFE coated
SG Iron	ASTM A395 ENP coated
Carbon Steel	ASTM A216 Gr. WCB PTFE coated
Carbon Steel	ASTM A216 Gr. WCB ENP coated
Carbon Steel	ASTM A351 Gr. CF8M PTFE coated
Carbon Steel	ASTM A351 Gr. CF8M ENP coated

FOR TMBV ONLY



## SEATS

Material	Description
PTFE	The most common seating material, suitable for almost all media, as it possesses excellent corrosion resistance.
15% Glass-filled (reinforced) PTFE	Stronger than PTFE seats and has higher temperature/pressure ratings
Polyfill	Carbon, Glass and Graphite-filled PTFE - suited for steam and thermal resistance and has good abrasion resistance. Good for high-cycle applications
PEEK	PEEK (Poly Ether Ether Ketone) is a material that demonstrates outstanding pressure capabilities at elevated temperatures - has excellent chemical and abrasion resistance.
Metal	Made of SS 316 and impregnated with Graphite for sizes of up to 50mm and hard-faced with Stellite for larger sizes.
Acetal Resin	Capable of handling extremely high pressures - not suited for Oxygen service

## BODY SEALS

Material	Description
PTFE	The most common body seal material, suitable for almost all media, as it possesses excellent corrosion resistance.
15% Glass-filled (reinforced) PTFE	Stronger than PTFE seats and has higher temperature/pressure ratings
PEEK	PEEK (Poly Ether Ether Ketone) is a material that demonstrates outstanding pressure capabilities at elevated temperatures - has excellent chemical and abrasion resistance.
Graphite	Used in fire-safe valves and in steam applications.

# ORDERING INFORMATION

Familiarity with our catalogue numbering is not necessary when specifying or ordering our valves. A full description of the valve provided by you is translated into a catalogue number as per the system shown below

SIZE (in mm)	SERIES	BODY & BALL COMBINATIONS	SEAT	ENDS	OPTIONS
8	<b>A44</b>	<small>Body &amp; Connector</small> <small>Ball / Stem</small>	<b>T</b> PTFE	<b>AT</b> - Screwed NPT	<b>No code</b> - Lever operated
10	<b>AF44</b>	<b>46</b> WCB/A105 SS316	<b>P</b> Polyfill	<b>BT</b> - Screwed BSPT	<b>El. ACT</b> - Electrical Actuator
15	<b>AF51</b>	<b>43</b> WCB/A105 SS304	<b>R</b> R-PTFE*	<b>KT</b> - Screwed Parallel	<b>Pn. ACT</b> - Pneumatic Actuator
20	<b>AF52</b>	<b>47</b> WCB/A105 Monel	<b>X</b> PEEK	<b>CT</b> - Socket weld	
25	<b>AF55</b>	<b>4D</b> WCB/A105 Hastelloy C	<b>D</b> Acetal	<b>FL150</b> - Flanged Class 150 RF	
32	<b>AF56</b>	<b>4Q</b> WCB/A105 410/CA15	<b>G</b> Graphite impregnated SS316	<b>FL300</b> - Flanged Class 300 RF	
50	<b>AB44</b>	<b>4U</b> WCB/A105 WCB (ENPctd)			<b>GO</b> - Gear operated
65	<b>AFB44</b>				<b>XS</b> - Extension spindle
80	<b>F15</b>				<b>XN</b> - Extension nipple
80	<b>F30</b>	<b>66</b> SS316 SS316			<b>LO</b> - Lock open
100	<b>5HP44</b>	<b>67</b> SS316 Monel			<b>LC</b> - Lock closed
125	<b>AW44</b>	<b>6D</b> SS316 Hastelloy C			<b>GA</b> - Gas over oil Actuator
150	<b>C44</b>	<b>36</b> SS304 SS316			<b>GT</b> - Gas type Actuator
200	<b>AT13</b>	<b>33</b> SS304 SS304			
250	<b>AD13</b>	<b>56</b> LCB SS316			
300	<b>AD14</b>	<b>LL</b> SS316L SS316L			
350	<b>TF15</b>	<b>RR</b> SS304L SS304L			
400	<b>TF30</b>	<b>AA</b> Alloy 20 Alloy 20			
450	<b>TR15</b>				
500	<b>TR30</b>				

\* R-PTFE - 15% Glass-filled PTFE

For any other special requirement, add **SPL** to the catalogue number and provide details.

The default ends for **AF51**, **AF55** and **F15** are **FL150** and for **AF52**, **AF56** and **F30** are **FL300**.

Examples : A44-46-T-BT  
AF51-66-T-FL150  
5HP44-46-D-AT  
TF30-JJQS-FL601-GO



## AUDCO INDIA LIMITED

Manufacturing Plant

Enathur, Kancheepuram 631 552, INDIA.

Tel : (04112) 64323. Fax : (04112) 64392.

Administrative Office

Mount-Poonamallee Road, Manapakkam, Post Bag 976, Chennai 600 089, INDIA.

Tel : (044) 2492323. Fax : (044) 2495055.

Website : [www.ailvalves.com](http://www.ailvalves.com)

Marketed by

## LARSEN & TOUBRO LIMITED

Valves Marketing Section

Post Bag 5247, Chennai 600 002, INDIA. Tel : (044) 8460141. Fax : (044) 8460728.

P.O. Box 619, Kolkata 700 071, INDIA. Tel : (033) 2822301/02/03/04/05. Fax : (033) 2827587.

P.O. Box 8119, Mumbai 400 051, INDIA. Tel : (022) 6541300. Fax : (022) 6541344.

P.O. Box 6223, New Delhi 110 015, INDIA. Tel : (011) 5931302. Fax : (011) 5438624.

